

## Melt~Profiler Concept

The process of Molding has changed considerably over the last decade relative to the microprocessor speeds of the Machines, use of servo valves, the implementation of electric injection and screw drives, expanded use of hot runner systems, more complicated molds, more demanding part applications and the proliferation of new Polymers. There has also been a considerable amount of work done on the best way to inject the polymer into the mold and more use of in-cavity sensors to control and or monitor the movement of the screw ram. The **Temp~Sense™ Melt~Profiler™II** system is a stand alone DAQ system that uses our unique micro-bead melt sensor that indicates the instantaneous melt temperature during the molding process to assist in perfecting a Decoupled molding strategy to mold perfect parts. Temp~Sense™

Placement of the Temp~Sense™ Sensor (US patents #7,585,166 & 6,649,095) into the Nozzle body, end cap or last to fill cavity will enable the processor to verify the thermal properties of the Polymer, promising 100% product verification. It's as simple as 1,2,3!

The Temp~Sense™ Melt sensor Fig. 1 takes the applied pressure (P) by the melt and measures the work applied to the polymer. The actual thermocouple meter readout displayed in our MPII DAQ unit shows the thermal energy being imparted to the polymer instantaneously for a unique "LOOK" Fig. 2, into the barrel.

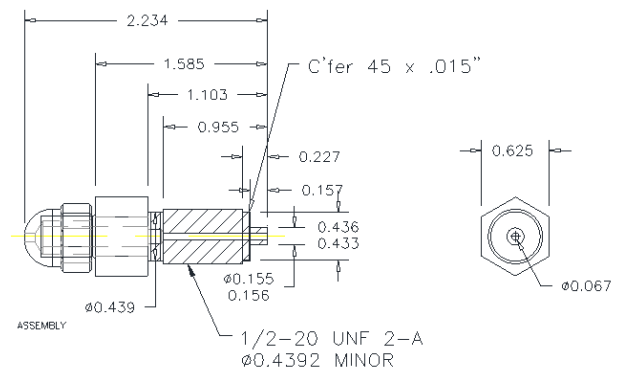

Fig. 1 ( Nozzle Sensor)

## Instantaneous Temp~Sense™ Melt Data

By inserting our sensor into the melt stream and connecting to our stand alone MPII DAQ, we display the instant work that is being applied to the polymer via the screw drive, heater bands, back pressure etc., giving you a "Look" into the barrel. Our real time LCD display can be set to graphical mode to see the effects of temperature vs. time. Data logger software is provided; use the included software to download, display, and save data to a file. The loggers also record maximum and minimum values. Logged temperature can also be exported to comma-separated values (.csv) and text formats for display and analysis in popular spreadsheet programs such as Microsoft Excel.



MPII DAQ

## What You will Learn

We are Bridging the Gap between the Machine and the Polymer by giving you a "Look" Inside of the Barrel with a direct one-to-one Melt Temperature Reading. The Temp~Sense™ Melt~Profiler™II can increase your Processing IQ by;

- 1) Placement of the "Bead" tangent with the Nozzle ID, displays the Total Thermal Energy Profile of the Polymer. The Thermal Profile can be equated to the Viscosity of the material and the readout is taken every 2 seconds for fast response time.



2

- 2) The Thermal Profile and Temp~Sense™ data is used to compare batch-to-batch inconsistencies which is a reflection of a change in molecular weight or perhaps a mechanical change in the machine components such as a bad heater band or inadvertent change in the nozzle orifice.
- 3) A Perfect Temp~Sense™ Profile can be used in the setup process and when moving molds from machine to machine. If the Viscosity Curve that is generated can be duplicated when moving to another machine then you are assured of producing a quality part.

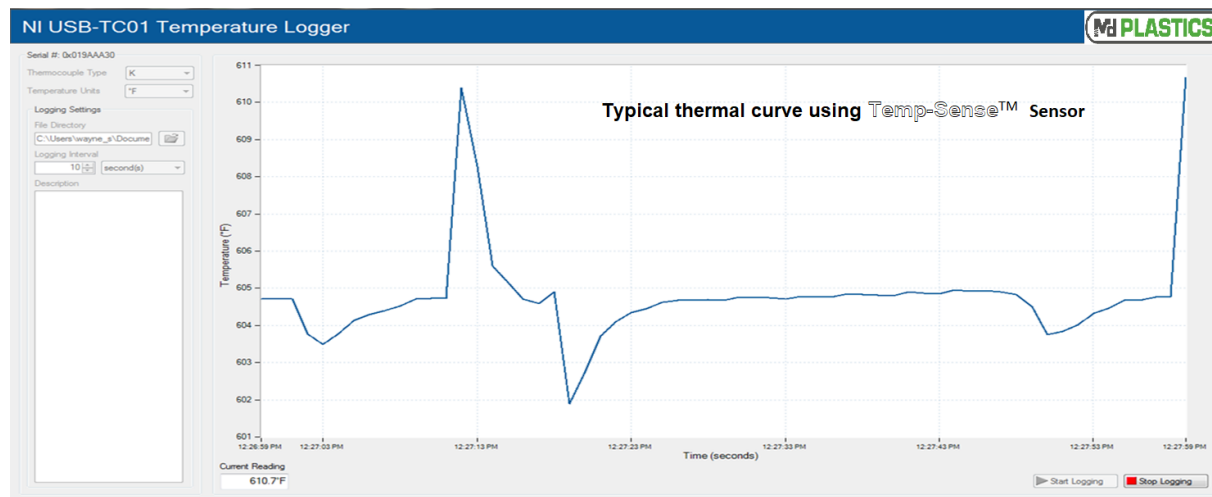

Fig. 2

## The Melt~Profiler™ II System Consists of:

- I. One stand alone MP II DAQ capable of reading two sensors . One Temp-Sense™ Nozzle Sensor (shown in fig. 1, 3).
- II. Your company will have to supply machining of our TC hole for your Nozzle Body or End Cap (or we can quote on the machining or a new nozzle) and a willingness to increase your processing IQ to produce perfect parts.
- III. The file management portion of our software allows the operator to pick the folder for storage, label the Production Run/Mold and each cycle is saved in a .csv file and time stamped for retrieval and further viewing in a Excel sheet .



Fig. 3

To Increase your processing IQ with a simple stand alone MP II DAQ system and Temp-Sense™ nozzle sensor, simply give us a call or visit our web-site and we will give you a “Look” inside the barrel such that the Industry has never before seen. With the information that we provide we guarantee that your processing knowledge will be put to better use and the gap between the molding machine and the polymer will be bridged!

