

## Performance Valve Evaluation

The Injection Molding process of filling the mold using a scientific methodology of determining the proper velocity and screw transfer points between fill, pack and hold to produce a qualified part assumes that the plasticating screw can supply a high level of melt temperature homogeneity and the screw tip (NRV) will shut off quickly and maintain shutoff through the full stroke of the screw. The principals at Md Plastics Incorporated have been focusing on the design and performance of the screw and NRV for over 30 years with the quest to perfect the melting and displacement process. Our patented “MDP” performance NRV has proven to provide a quick and concise shutoff under a variety of conditions, a comprehensive analysis using an independent processor/fabricator is described below.

### Test Conditions

A very accomplished custom Midwest Injection Molding Company sought to find a solution to poor part quality, frequent NRV changes that were application specific and a longer lasting component. They have been using a sliding ring free flow design which is not unlike others that are provided by OEM’s and are sold by various aftermarket suppliers for a majority of their standard processes and a “QSO”™ poppet design for gas assist processes. A series of tests were conducted on a 90mm diameter “MDP” performance sliding ring design for a Mitsubishi Molding Machine for the evaluation.

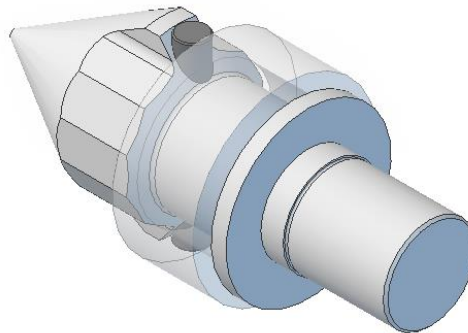

Patent # 7,527,493

Test #1 was conducted with a 20% Glass filled 12 MI PP material, the results are as follows;

DESIGN: “MDP” PERFORMANCE SLIDING RING

PART WT. GRAMS: 505

DECOMPRESSION	CUSHION	PART WT. VARIATION GRAMS
18mm	12.2-15.2 mm	.8
ZERO	10.4-13.2 mm	1.2

DESIGN: 3-PIECE SLIDING RING

PART WT. GRAMS: 505

DECOMPRESSION	CUSHION	PART WT. VARIATION GRAMS
18mm	1.6-12.6 mm	3.4
ZERO	SHORT SHOTS	

The data proves that our design shut off quicker than the 3-pc. Sliding Ring design was more precise and worked very well without the use of melt decompression.



Test # two was with a 20% Glass Filled Polycarbonate with an in-mold Gas Assist application. The process requires that the screw bottom out each shot so a proper distribution of gas disperses throughout the part. The results are as follows;

DESIGN: "MDP" PERFORMANCE SLIDING RING

DECOMPRESSION	INJECTION STROKE mm	PART WT. GRAMS/MIN.	PART WT. GRAMS/MAX.	RANGE	STD. DEV.
15mm	140	987.7	990.7	3.00	1.083
5mm	140	971.8	973.2	1.40	.300
ZERO	140	969.8	971.1	1.30	.400

DESIGN: "QSO" POPPET

DECOMPRESSION	INJECTION STROKE mm	PART WT. GRAMS/MIN.	PART WT. GRAMS/MAX.	RANGE	STD. DEV.
15mm	145	989.6	997.2	7.60	1.9
5mm	145	977.0	981.3	4.3	1.10
ZERO	145	969.6	971.6	2.0	1.10

It is important to note that the "QSO" Poppet Valve was run first with a 145mm stroke, when the "MDP" valve was installed the part weight immediately increased to 1012.4 grams which proves that the "MDP" valve shut off quicker than the "QSO" Valve. Since the process dictates that that the screw needs to bottom out, the stroke had to be reduced to 140mm. If a volumetric evaluation is made using 1.2g/cm<sup>3</sup> for density of the polymer, the part weight would be 1069.9 grams, proving that the "MDP" valve shuts off quickly and stays shut through the full stroke. The data also supports a more precise operating component.

Test # three was with a 30% Glass Filled PA 6/6 material. The results are as follows;

DESIGN: "MDP" PERFORMANCE SLIDING RING

DECOMPRESSION	INJECTION STROKE mm	PART WT. GRAMS/MIN.	PART WT. GRAMS/MAX.	RANGE	STD. DEV.
15mm	50	330.7	331.9	1.20	.30
10mm	52	331.0	332.0	1.60	.40

DESIGN: "QSO" POPPET

DECOMPRESSION	INJECTION STROKE mm	PART WT. GRAMS/MIN.	PART WT. GRAMS/MAX.	RANGE	STD. DEV.
15mm	70	328.8	337.7	8.90	2.50
10mm	70	331.9	337.3	5.4	1.60

DESIGN: 3-PIECE SLIDING RING "FREE FLOW"

DECOMPRESSION	INJECTION STROKE mm	PART WT. GRAMS/MIN.	PART WT. GRAMS/MAX.	RANGE	STD. DEV.
15mm	62	327.1	339.5	12.4	2.9
10mm	62	327.6	338.1	10.5	2.1



The 3-piece Free Flow design experienced numerous short shots and flashed parts with 15mm decompression and two short shots with 10mm decompression. The “QSO” design required a 70mm stroke, the 3-piece a 62mm stroke while the “MDP” design only required a 52mm stroke, which indicates that the shutoff was quicker with the “MDP” design.

Since its inception, the “MDP” performance NRV has proven that it is the most precise sliding ring NRV in the industry virtue of its unique geometry and low pressure drop in applications from 16mm through 240mm in diameter while covering the gamut of resin Viscosity and Injection Velocity.

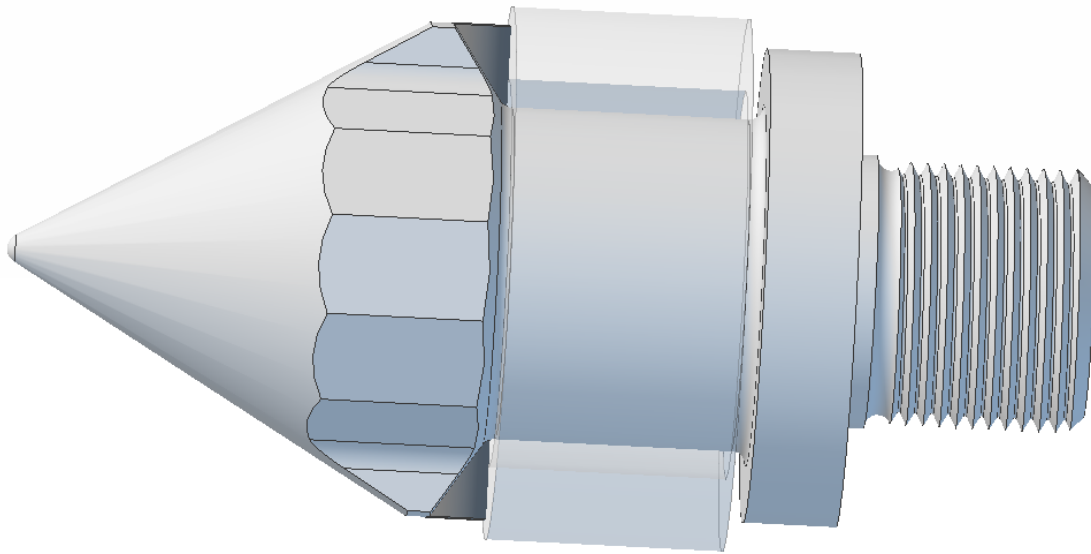

**MDP™** 

***Performance Non-Return Valve***

*Patent # 7,527,493*

